

Installation Instructions



Micro Cement Linear Kit



Guarantee

If installed correctly by a competent person and used for normal wetroom applications the Maxxus (and membrane if supplied by us) have a life-of-tile guarantee (if grout lines are maintained). No guarantee is offered where this is not the case.

Installation Overview

These instructions assume the wetroom has been appropriately designed and all plumbing and electrical work is to building regulations. These instructions will cover the most typical level floor installations on suspended timber or solid concrete floors. For raised floor areas the instructions can be applied where appropriate.

The Maxxus is a load bearing deck which can sustain a load of 470kgs over 400mm joist centres without deflection and as such require no under boarding

Installation on Timber Floors

1. Remove the floorboards to expose the joists in the area where the deck will be fitted.
2. Inspect the existing joists and if in doubt remedial action should be taken to ensure the floor is strong and free of movement.
3. If joist centres are 400mm or less the Maxxus can be laid straight over the existing joists without under boarding.
4. If the joist centres are over 400mm install additional noggins for support.
5. Install noggins around the drain slot.
6. All edges of the deck must be supported.
7. Lay the tray in position and consider the waste location and connection.
8. Connect the waste using the method shown overleaf.
9. To fix the Maxxus pilot drill and screw down securely with appropriate wood screws.
10. Check to make sure there is no movement and that the tray is level.
11. Use additional fixings if movement is detected, screw heads must be countersunk into the tray.

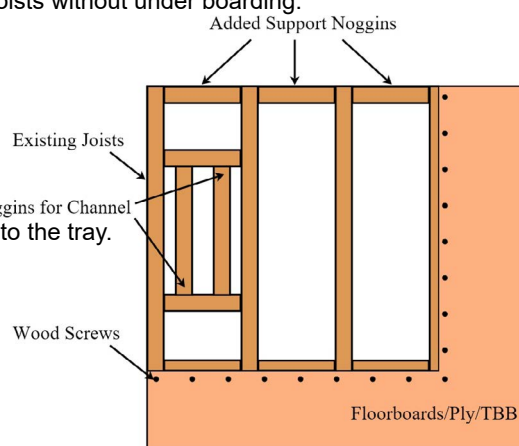

Installation on Existing Concrete Floors

1. If inseting the tray, the area beneath the deck must be cut and chiseled out to accommodate the deck, drain and waste pipe.
2. Read overleaf the waste installation method.
3. Connect the bottom section of the drain to pipework.
4. Bed the deck down on tile adhesive or sand and cement.
5. Finish installing the drain.
6. Ensure the deck is level then allow to fully dry.
7. Pilot drill the deck and securely screw down.
8. Check to make sure there is no movement and that the tray is level.
9. Use additional fixings if movement is detected, screw heads must be countersunk into the tray.

Installing the Purus Living Linear Drain - Micro Cement

The Purus Living Linear box contains some components that are not required for installation into the Maxxus Linear Deck. The only components required are as per the diagram.

Waste connections can be made in the following ways:
Access from the underneath.
Connecting a short length of pipe to the trap to enable final connection outside the deck area.

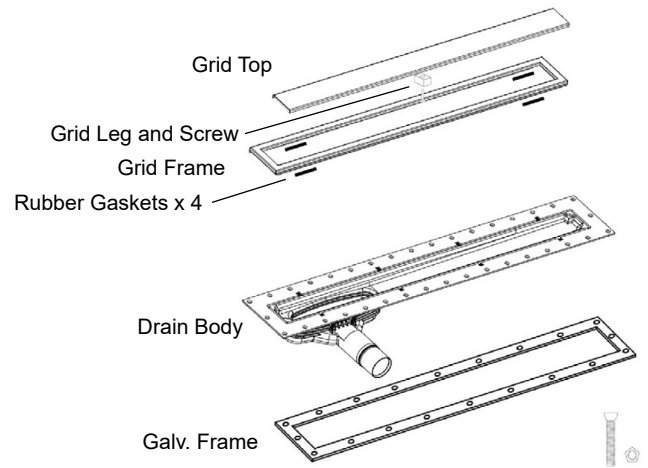

The drain body is set into the rebate from the top of the Maxxus (the side with the slopes). The drain body is fixed into position using the clamping frame on the underside of the Maxxus and bolted through. The bolts provided should be spaced out evenly around the drain body. Pilot drill the holes through the drain body and Maxxus deck and bolt through. Do not use power tools and do not over tighten. See diagram below.

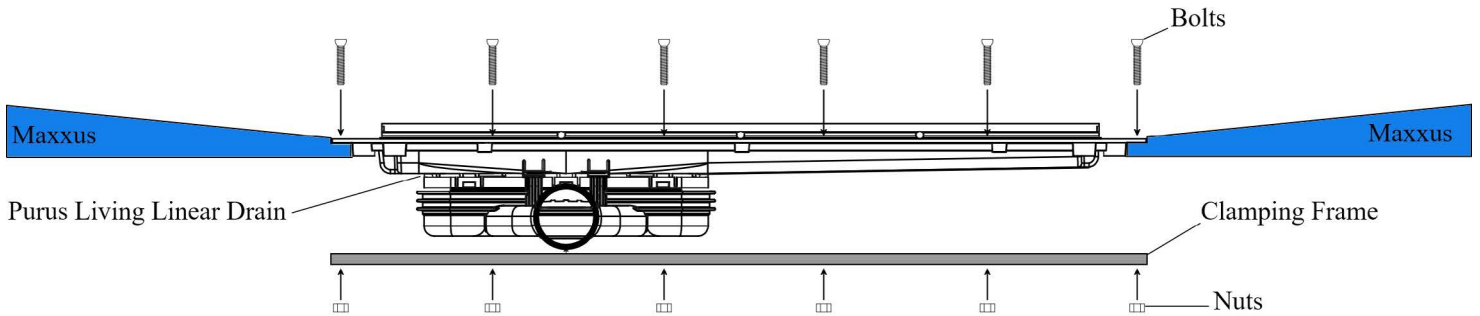

Depending how the deck is installed the floor may need to be levelled to the same height as the deck, this may be done using plywood or screed.

Do not remove the protective film until the micro cement has been laid

1. Install the drain into the tray/floor and tank as required.
2. Push the 4 x Rubber gaskets on to the grid Frame.
3. Apply sealant to drain body where the frame is to be fitted.
4. Press fit grid frame into drain body.
5. Check grid frame is seated on drain body correctly.
6. Ensure a good seal between the drain and frame.
7. Allow sealant to dry.
8. Lay micro cement.
9. Remove protective film from grid frame.
10. Remove any excess residue using a non abrasive cloth and hot soapy water.
11. Discard white plastic packer.
12. Screw grid leg into bottom of grid top.
13. Insert grid top into the drain, grid top will only fit in one orientation, if movement occurs, turn the grid around.

